

# VHF Wideband Low-Profile Antenna

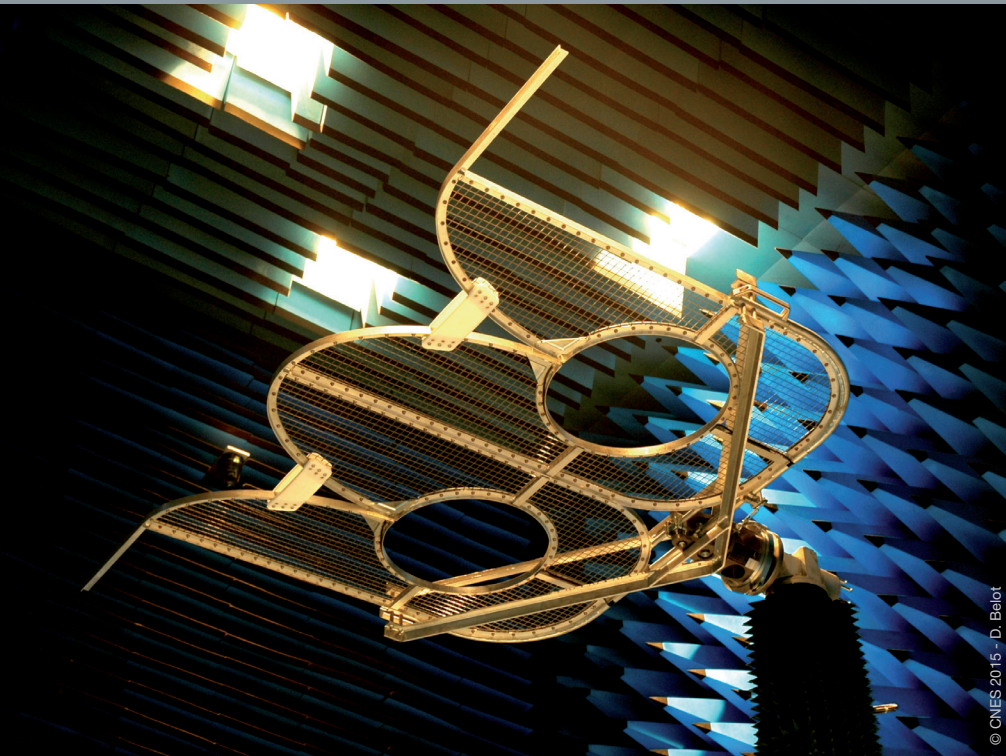

© CNES 2015 - D. Belot

Typical 3D radiation pattern

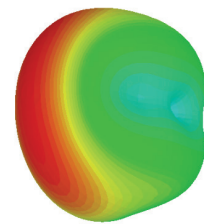

## SOLUTION FOR

- Gain and polarization reference
- Antenna VHF Measurements

## Main features

### Technical performance

- Wide bandwidth
- Linear polarization
- Low loss and high efficiency
- Low return loss / VSWR

### Design

- Low profile
- Aluminium structure
- Lightweight and handles for easy handling
- High stiffness

### Surface treatment

- Hard anodic oxidation coating on the mounting flange
- For indoor use

### Repeatability

- Robust mechanical design
- Optimized low mechanical deformation due to the dead load
- Reliable cables and coaxial connectors

### Delivered documents

- Measured return loss data

## Product configuration

### Equipment

- Antenna
- Mounting flange

### Related services

- Calibration and maintenance
- Outdoor installation customization

Included  Optional

## Electrical characteristics

Part number	Type of antenna	Frequency range [MHz]	Polarization	Gain at center frequency [dBi]	Directivity [dBi]	VSWR	Return loss [dB]	Cross-polar discrimination [dB]	Impedance [Ohms]
WLPA40	Low Profile Antenna	40 – 400	Single Linear	8	2 to 9	< 2.3	< -8	> 30	50

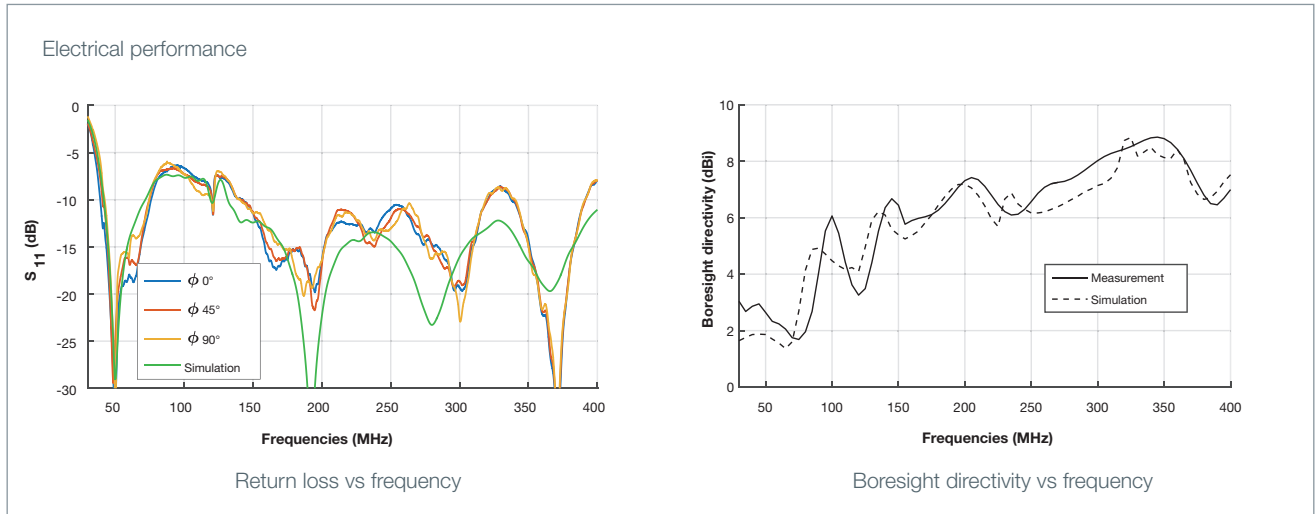

Measured S11 performances for 3 different roll positions of WLPA40 reference antenna: the mechanical stability over a roll scan is proven by the high correlation between plots

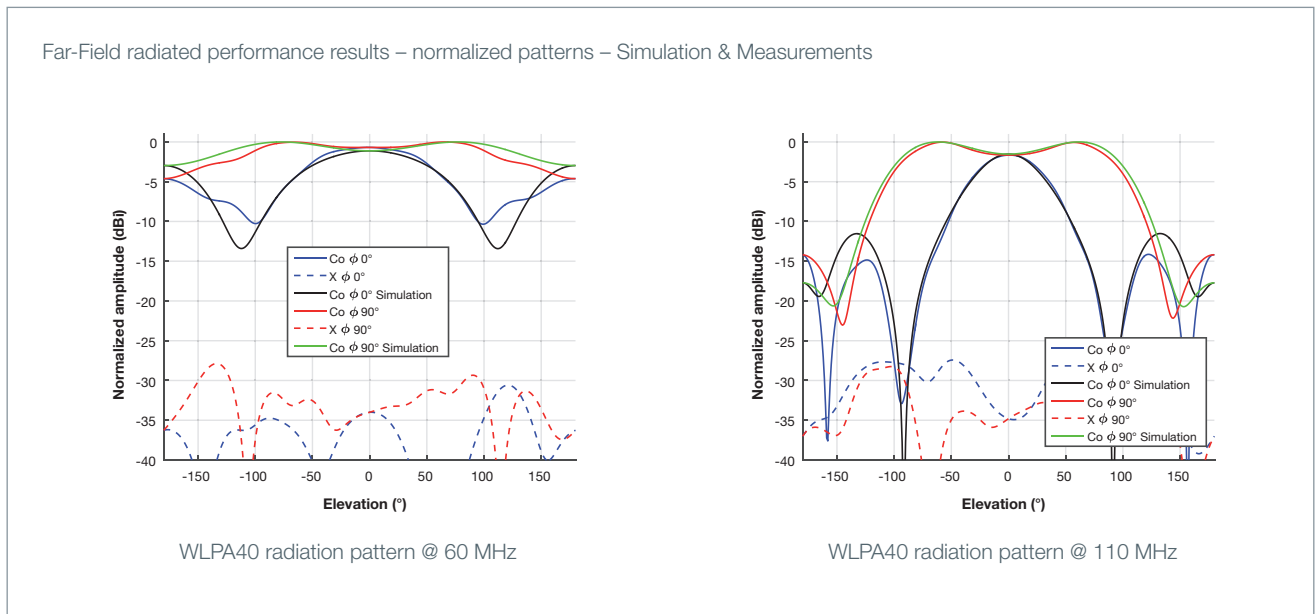

Radiated performances were measured in the single probe Near-Field system installed in the CATR of CNES, Toulouse by using the WPD50 probe (see MVG datasheet: VHF wideband dual polarized probe)

## Mechanical characteristics

Part number	Dimensions (L x H x W) [mm]	Weight (approx.) [kg]	RF Connector	Material	Color	Interface
WLPA40	3000 x 1947 x 30	50	SMA Female (N-type optional)	Aluminium	Custom	Custom

Dimensional drawing [mm]

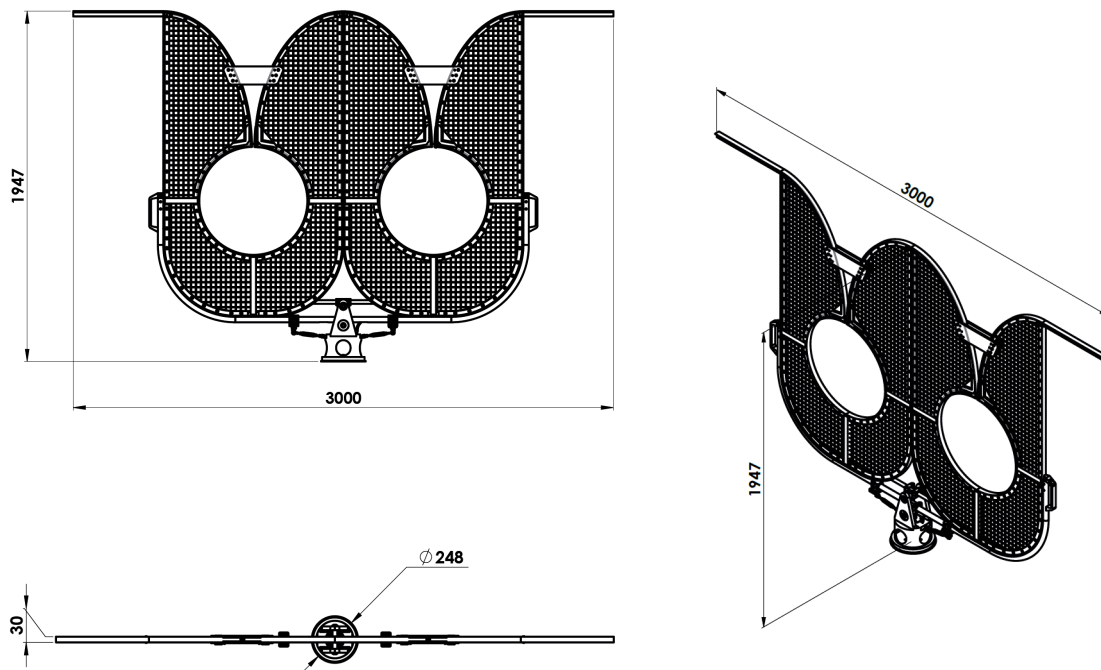

## REFERENCES

- G. Le Fur, G. Robin, D. Belot, L. Feat, N. Adnet, L. Duchesne, K. Elis., A. Bellion, R. Contreres, "Implementation of a VHF Spherical Near-Field Measurement Facility at CNES". Antenna Measurement Techniques Association; AMTA, Oct 2016, Austin, United States.



**Contact your local sales representative for more information**

[salesteam@mvg-world.com](mailto:salesteam@mvg-world.com)

[www.mvg-world.com](http://www.mvg-world.com)