

Antenna/Positioner Interface

The standard SOI interface allows for precise and easy positioning of any MVG standard antenna with a 60 mm or 110 mm flange onto an MVG measurement system. The interface consists of two parallel flanges aligned by three precision rods. The assembly is also equipped with a bubble level. The MVG circular interface allows the user to center the antenna with very high accuracy. Antennas with the 60 mm flange are fastened by four M4 screws while antennas with the 110 mm flange are fastened by four M5 screws. The alignment is determined by a precision pin.

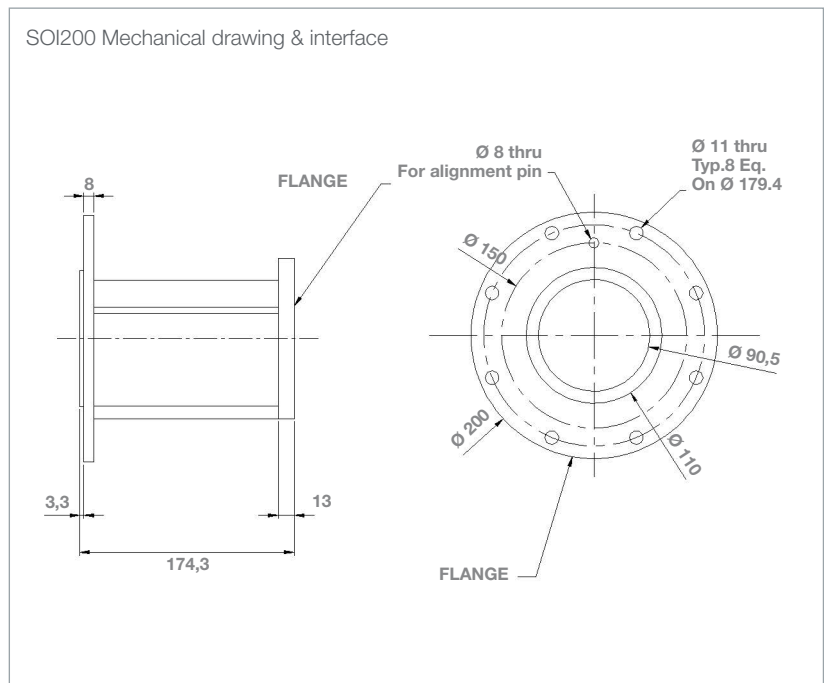

Contact your local sales representative for more information
www.mvg-world.com/antennas
salesteam@mvg-world.com

