

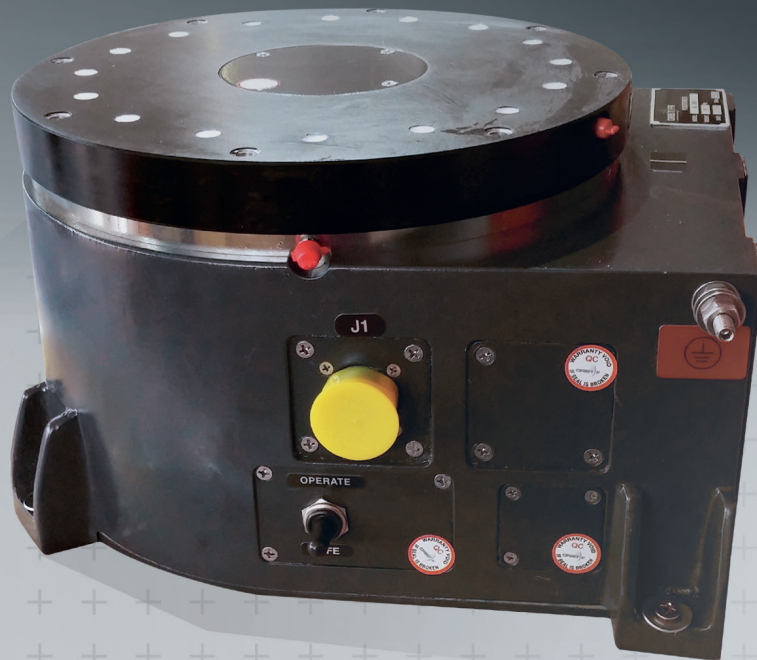

LEGACY SERIES AZ

Azimuth Positioners

LIGHT DUTY



AL-061-1 • AL-161-1 • AL-461-1 • AL-360-1 • AL-560-1 • AL-561-1 • AL-760-1 • AL-761-1 • AL-760-1-S

The **MVG-Orbit/FR Legacy Series Azimuth Positioners** provide accurate, balanced rotation, and controllable velocity. Their rugged yet straight-forward construction ensures maximum reliability and trouble-free operation, yielding the best size and weight/performance ratio.

Typically, the unit includes the body, precise slew bearings, DC motor, gear reducer, encoder/synchro, and limit switch assembly. The turntable surface is designed with a threaded mounting hole pattern for ease of use. A Safe/Operate switch is included to ensure safety.

APPLICATIONS

- General purpose positioning subsystems
- Far-field & near-field antenna measurements
- Indoor & outdoor use

PRODUCT HIGHLIGHTS

- Broad selection – 9 models
- Operating loads up to 2000 lbs (910 kg)
- Turntable diameters ranging from 2.6 in to 126 in (66-320 mm)
- Excellent angular position accuracy
- Low backlash design
- Precision bearings
- Closed loop servo control
- Industry-standard wiring
- Tachometer/encoder for optimum speed regulation & control
- Wide operating temperature range:
 - 4° F to 140° F (- 20° C to 60° C)
- Fully enclosed design of drive gear train & data take-off
- Wide variety of available options

Specifications - Legacy Series AZ Light Duty Positioners

PARAMETER

UNITS

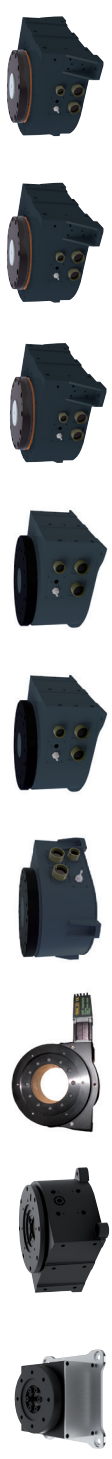

AL-061-1 217-0350-4 AL-161-1 215-0230 AL-461-1 214-0430 AL-360-1 07-0221 AL-560-1 05-0097 AL-561-1 05-0097 AL-760-1 05-0614 AL-761-1 05-0614 AL-760-1-S 05-0614

Dimensional Drawing Number	DCD	217-0350-4	215-0230	214-0430	07-0221	05-0097	05-0097	05-0614	05-0614	05-0614	05-0614	05-0614
----------------------------	-----	------------	----------	----------	---------	---------	---------	---------	---------	---------	---------	---------

OPERATIONAL

Bending moment	ft-lbs	15	100	434	300	800	800	3,000	3,000	3,000	3,000	6,000
	kg-m	2	14	60	41	111	111	415	415	415	415	830
Vertical load	lbs	12	50	440	300	800	800	2,000	2,000	2,000	2,000	2,000
	kg	5	23	200	136	360	360	910	910	910	910	910
Delivered torque	ft-lbs	7.2	50	40	90	150	100	500	500	375	500	500
	kg-m	1	7	6	12	20	14	70	70	50	70	70
Withstand torque	ft-lbs	35	75	60	120	210	210	600	600	600	600	600
	kg-m	5	10	8	20	30	30	80	80	80	80	80
Drive power	hp	1/20	1/20	1/20	1/8	1/8	1/8	1/3	1/3	1/3	1/3	1/3
Nominal speed	rpm	1	1.5	1.25	2.6	2	3	1.5	1.5	2	2	1.5
Standard angle Transducer format		Incremental encoder	Incremental encoder	Incremental encoder	Incremental encoder	Incremental encoder	Incremental encoder	Incremental encoder	Incremental encoder	Incremental encoder	Incremental encoder	Incremental encoder
Standard accuracy	deg	± 0.04	± 0.04	± 0.03	± 0.04	± 0.03	± 0.03	± 0.03	± 0.03	± 0.03	± 0.03	± 0.03
Maximum backlash	deg	0.06	0.06	0.06	0.05	0.05	0.05	0.05	0.05	0.05	0.05	0.05

PHYSICAL

Height	in	2.8	5.3	4.1	7.2	8.5	8.5	10.3	10.3	10.3	10.3	10.3
	mm	71	135	105	184	215	215	262	262	262	262	262
Weight	lbs	11	22	33	45	80	80	143	143	143	143	297
	kg	2	10	15	20	36	36	65	65	65	65	135
Turntable diameter	in	3.74	7.9	9	10.3	12.5	12.5	12.6	12.6	12.6	12.6	12.6
	mm	95	200	228	262	318	318	320	320	320	320	320

ENVIRONMENTAL

Operating temperature		- 4° F to 140° F (- 20° C to 60° C)										
-----------------------	--	-------------------------------------	--	--	--	--	--	--	--	--	--	--

PARAMETER	UNITS	AL-061-1	AL-161-1	AL-461-1	AL-360-1	AL-560-1	AL-561-1	AL-760-1	AL-761-1	AL-760-1-S
-----------	-------	----------	----------	----------	----------	----------	----------	----------	----------	------------

OPTIONS

EN002	Direct incremental encoder (high accuracy)	-	-	-	-	Opt	Opt	Opt	Opt	Opt
EN003	Direct absolute encoder (high accuracy) ²	-	Opt	-	Opt	Opt	Opt	Opt	Opt	Opt
EN004	Absolute encoder	-	Opt	Opt	Opt	Opt	Opt	Opt	Opt	Opt
SR	Slip ring ⁴	*5	*5	*5	SR051L SR101L SR201L	SR051L SR101L SR201L SR301L	SR051L SR101L SR201L SR301L	SR051L SR101L SR201L SR301L	SR051L SR101L SR201L SR301L	SR051L SR101L SR201L SR301L
RJ	Rotary joint ⁴	RJ18L RJ26L RJ40L RJ50L	RJ12UL RJ18L RJ26L RJ40L RJ50L	RJ12UL RJ18L RJ26L RJ40L RJ50L	RJ12L RJ18L RJ26L RJ40L RJ50L	RJ12L RJ18L RJ26L RJ40L RJ50L	RJ12L RJ18L RJ26L RJ40L RJ50L	RJ12L RJ18L RJ26L RJ40L RJ50L	RJ12L RJ18L RJ26L RJ40L RJ50L	RJ12L RJ18L RJ26L RJ40L RJ50L
TH	Central thru-hole inner diameter	S	S	S	TH002 TH003	TH002 TH003	TH002 TH003	TH002 TH003	TH002 TH003	TH002 TH003
	in	1	1.8	3.5	2.3	2.3	2.3	3.0	3.0	3.0
	mm	25	44.5	90	57.2	57.2	57.2	76.2	76.2	76.2
EX	Internal harnessing	-	-	-	EX002	EX002	EX002	EX002	EX002	EX002
CF	Connector format	-	-	-	CF001 CF002	CF001 CF002	CF001 CF002	CF001 CF002	CF001 CF002	CF001 CF002
LS	Leveling screw (set)	-	-	-	-	-	-	LS001-3	LS001-3	LS001-3
ST	Stow lock	-	-	-	-	-	-	-	-	-
MM	Mounting thread	MM002 MM003	MM002 MM003	MM002 MM003	MM002 MM003	MM002 MM003	MM002 MM003	MM002 MM003	MM002 MM003	MM002 MM003

(-) N/A S Standard Opt Optional

Supplied Accessories

Digital Documentation Set

User manual (installation, setup, operation & maintenance)

Technical Notes

- 1** All accuracy data is based on no-load conditions.
Contact MVG-ORBIT/FR for accuracy under load conditions
- 2** Positioner size might be increased with ABS encoder option implemented. Please consult MVG-Orbit/FR.
- 3** AL-360 and larger models are equipped with adjustable limit switches capable of approx 20° to 90° total travel. When rotary joint and slip ring options are specified, limit switches remain but are electrically disabled. Single-axis positioners are factory-set at:
 - Azimuth axis: 400° (± 200°)
- 4** Slip ring & rotary joint option:
 - Certain slip ring options may require an extension cap that protrudes above the turntable surface. Positioner height may increase. Consult ORBIT/FR
 - Slip ring contacts are provided with dedicated connectors
 - When rotary joint and/or slip ring options are specified, no central thru-hole is available to the user. Option TH002 and TH003 are available in lieu of rotary joint and/or slip ring options
- 5** Slip ring option in the smallest models (AL-061-1,161-1,461-1) are unique and need special attention.
Please consult MVG-Orbit/FR
- 6** Mounting thread - mm is standard (002), please specify opt MM003 for other types.
- 7** AL-061, AL-161, and AL-461 models:
 - Contain restricted limit travel settings of ± 200°
 - Rated for indoor use only
 - Encoder accuracy is ± 0.03°
 - Interface readout - incremental encoder (synchro not available)
- 8** All models are delivered standard with incremental encoder
- 9** Other STD turntables with interface for feed are available.
Consult MVG-Orbit/FR for details.

AL-360-1

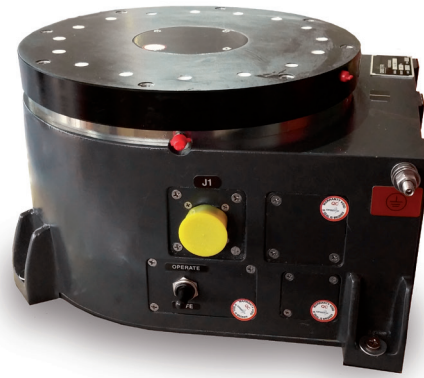

AL-560-1

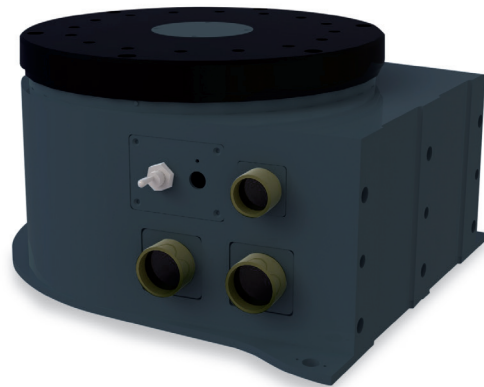

Dimensional drawing - AL-360-1 *

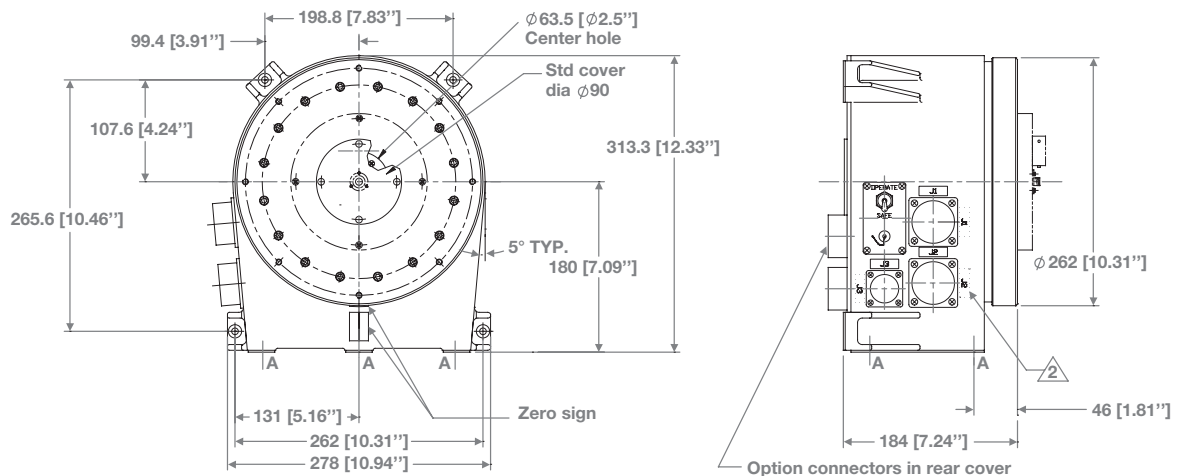

* Example drawing for general reference, please consult MVG-Orbit/FR for ICD.